

## ST48-JAUV.100

Temperature controller

Order number 169763

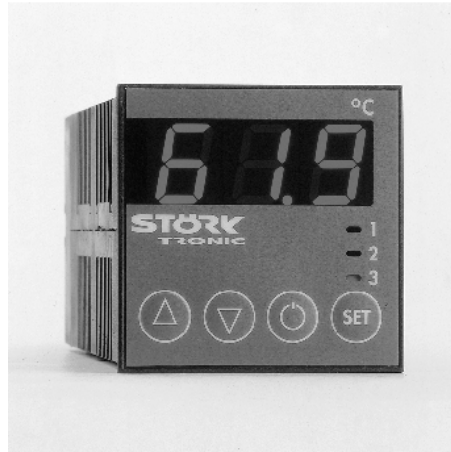

### Wiring diagram

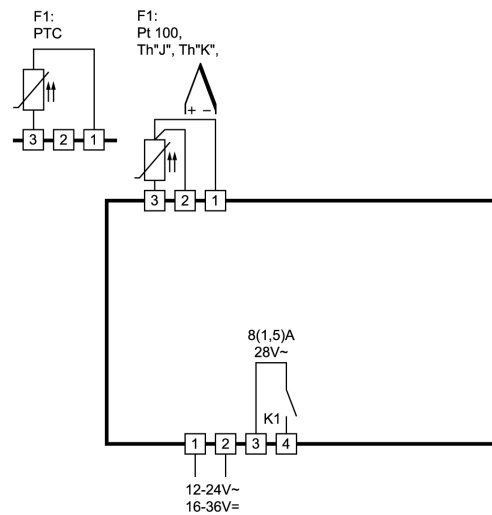

### Product description

The controller ST48-JAUV.100 was developed for simple thermostatic controls. The setpoint, all parameters of the controller and the activation of the stand-by function are set on a four-field plastic foil keyboard. The controller can be supplied with a tension of 12-24V AC. The installed relay has a maximum electric Ohm load of 8A. Inductive loads can be switched up to 1,5A.

**Sensor:** universal sensor input

**Range:** dependent on the type of sensor

**Front size:** 48mm x 48mm

**Panel cut-out:** 45,2mm x 45,2mm

**Tightness:** front IP65

**Connector:** plug and socket

ST 48...

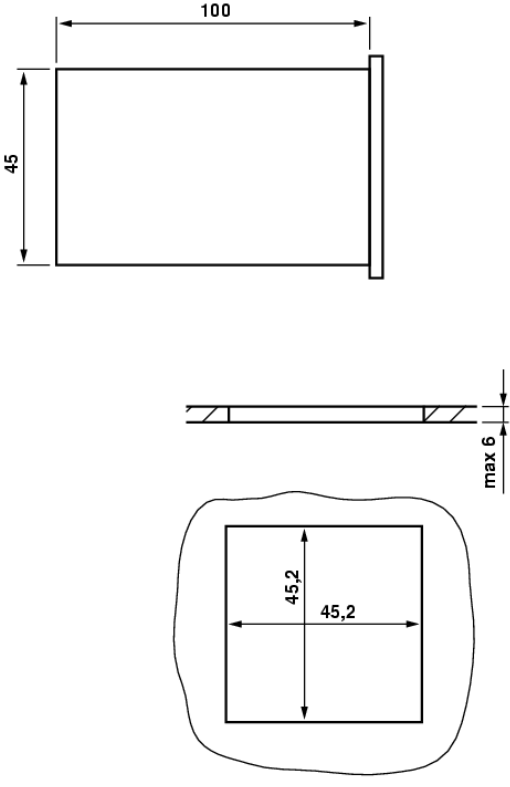
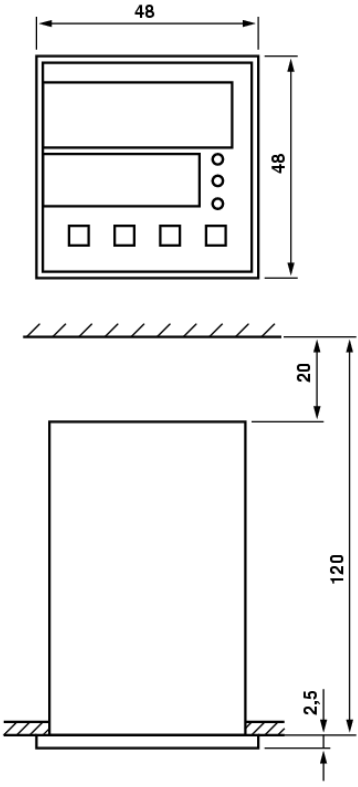

## SOFTWARE .100

### Adjustment options



#### **Key UP**

Pressing this key you can increase the parameter or parameter value or scroll the parameter list.



#### **Key DOWN**

Pressing this key you can decrease the parameter or parameter value or scroll the parameter list. At alarm the buzzer function can be switched off with this key.



#### **Standby key (function key 1)**

Switching the controller on or off. After net interruption, parameter H17 is automatically set.



#### **Key SET**

Holding this key, the desired value is indicated. Additionally, this key is used for setting parameters.

### First control level:

#### **Parameter setting of the control setpoint**

The control setpoint C1 is accessible directly with SET key. Pressing also the UP or DOWN key it can be adjusted.

Parameter	Function description	Adjustment range	Standard setting	Custom setting
<b>C1</b>	Control setpoint 1 for control circuit 1 and/or PID-regulation	C10...C11	0.0 °C	
<b>C2</b>	Control setpoint 2 for control circuit 1 (*)	C10...C11	0.0 °C	

\* The activation of the second setpoint of circuit 1 C2 is indicated on the display with a flashing point to the right. It can either be activated via switching entrance or with *function key 1* (depending on parameter).

#### **Software version**

The version number of the software will show when pressing SET + UP + DOWN at the same time.

## Menu level

When simultaneously pressing the UP and DOWN key for at least 4 seconds, the controller changes to menu level. It consists of several sub-menus listed by the respective initial letter followed by 2 lines (e.g. C -- for the C-level).

Parameter	Sub-menu	Function
C--	Controller level	Application parameters
b--	Intermediate level	Connecting parameters
H--	Hardware level	Hardware parameters
d--	Defrost level	Defrosting parameters (control circuit 1)
A--	Analogue level	Parameter for analogue in- and outputs

## Adjustment of control parameters

Selection of the sub-menu is effected by scrolling with the UP and DOWN key. Upon pressure of the SET key the password of the respective level is requested. The password must be adjusted by additionally pressing the UP or DOWN key (standard value: 0).

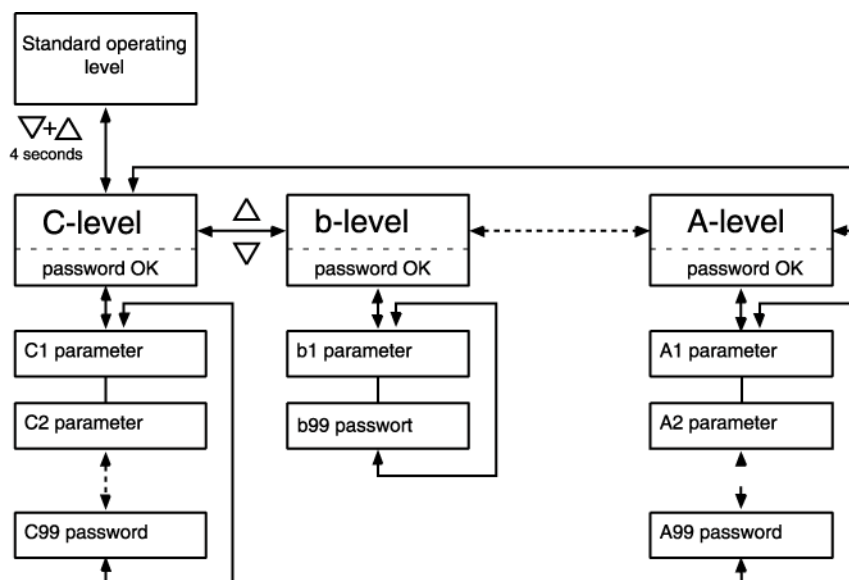

The last parameter of the respective sub-menu (e.g. C99, b99...) corresponds to the current password of this level and can be changed there.

**NOTE:** Forgetting the password requires sending the controller to Stoerk Tronic.

If the password is correct, the display jumps to the sub-menu and shows the first listed parameters when the set key is released. Pressing the SET key, the value of the selected parameter is indicated. Additionally pressing the UP or DOWN key, the value can be adjusted. Releasing all keys, the new value is saved long term.

If UP and DOWN keys are simultaneously pressed again for at least 4 seconds, the display switches to the menu level again. Upon repeated pressing for 4 seconds or no pressing of any key for more than 60 seconds, the system jumps back to the initial state.

### The C-level (controller)

This level contains the application parameters.

#### Thermostat 1

Parameter	Function	Adjustment range	Standard setting	Custom setting
<b>C1</b>	Setpoint control circuit 1	-99 ... 999°C	0.0°C	
<b>C2</b>	Setpoint control circuit 1 (*)	-99.0 ... 99.0°K	0.0°C	
<b>C3</b>	Offset for C1/C2	-99.0 ... 99.0°K	0.0°K	
<b>C4</b>	Switching sense control circuit 1	0: heating function 1: cooling function	0	
<b>C5</b>	Hysteresis control circuit 1	0.1 ... 99.9°K	1.0°K	
<b>C6</b>	Hysteresis mode control circuit 1	0: symmetrical 1: one-sided	0	
<b>C7</b>	Minimum action time control circuit 1 "ON"	0 ... 400 sec.	0 sec.	
<b>C8</b>	Minimum action time control circuit 1 "OFF"	0 ... 400 sec.	0 sec.	
<b>C9</b>	Function control circuit 1 at sensor error	0: relay off 1: relay on	0	
<b>C10</b>	Control range limitation, minimum Setpoint 1	-99.0°C ... C11	-99.0°C	
<b>C11</b>	Control range limitation, maximum Setpoint 1	C10 ... 999.0°C	999.0°C	

\* The activation of the second desired value C2 is indicated on the display with a flashing point to the right. It can either be activated via switching entrance or with *function key 1* (depending on parameter).

#### Thermostat 2

Parameter	Function	Adjustment range	Standard setting	Custom setting
<b>C21</b>	Setpoint control circuit 2 (b1=0)	-99...999°C	0°C	
<b>C23</b>	Delta W2 (b1=1)	-99...99°K	0°K	
<b>C24</b>	Switching sense control circuit 2	0: heating function 1: cooling function	0	
<b>C25</b>	Hysteresis control circuit 2	0.1 ... 99.9°K	1°K	
<b>C26</b>	Hysteresis mode control circuit 2	0: symmetrical 1: one-sided	0	
<b>C27</b>	Minimum action time control circuit 2 "ON"	0...400 sec.	0 sec.	
<b>C28</b>	Minimum action time control circuit 2 "OFF"	0...400 sec.	0 sec.	
<b>C29</b>	Function control circuit 2 at sensor error	0: relay off 1: relay on	0	

## Thermostat 3

Parameter	Function	Adjustment range	Standard setting	Custom setting
C41	Sollwert control circuit 3 (b2=0)	-99...999°C	0.0°C	
C43	Delta W3 (b2=1)	-99.0 ... 99.0°K	0.0°K	
C44	Switching sense control circuit 3	0: heating function 1: cooling function	0	
C45	Hysteresis control circuit 3	0.1 ... 99.9°K	1.0°K	
C46	Hysteresis mode control circuit 3	0: symmetrical 1: one-sided	0	
C47	Minimum action time control circuit 3 "ON"	0...400 sec.	0 sec.	
C48	Minimum action time control circuit 3 "OFF"	0...400 sec.	0 sec.	
C49	Function control circuit 3 at sensor error	0: relay off 1: relay on	0	

## Alarm circuit

Parameter	Function	Adjustment range	Standard setting	Custom setting
C61	Lower alarm value	-99.0 ... C62	-10.0	
C62	Upper alarm value	C61 ... 999.0	10.0	
C63	Alarm functions	0: Boundary alarm, relative boundaries 1: Boundary alarm, absolute boundaries 2: Range alarm, relative boundaries 3: Range alarm, absolute boundaries 4: Boundary alarm, relative boundaries, alarm invers 5: Boundary alarm, absolute boundaries, alarm invers 6: Range alarm, relative boundaries, alarm invers 7: Range alarm, absolute boundaries, alarm invers	0	
C64	Special function at boundary alarm	0: not active 1: flashing display 2: buzzer 3: buzzer + flashing display 4: like 3, buzzer can be cancelled 5: like 4, restarts after 10 min. 6: like 4, restarts after 30 min.	0	
C65	Hysteresis alarm circuit	0.1 ... 9.9°K	1°K	

## Password

Parameter	Function	Adjustment range	Standard setting	Custom setting
C99	Password C-level	-99...999	0	

### Parameter description C-level:

#### C1: Setpoint control circuit 1

This value corresponds with the setpoint set at the first control level.

#### C2: Setpoint control circuit 1 (thermostat) at closed switching input

By closing switching input E1, setpoint C1 can be switched to a setpoint C2.

The setpoint C2 can only be accessed if entrance E1 is closed. The setpoint C2 can only be activated, if the external input is configured for setpoint change-over.

#### C3: Offset for C1/C2

This adjusted value will build the difference to the setpoint for control circuit 1, i.e. there is no regulation according to the pre-set value, but according to the sum of desired value and the value of C3.

#### C4: Switching sense control circuit 1

The switching sense for the relays, i.e. cooling or heating function, can be programmed independently. Heating function means that the contact falls as soon as the pre-set setpoint is reached, thus power interruption. At cooling function the contact only tightens, if the actual value is above the required setpoint.

#### C5: Hysteresis control circuit 1

The hysteresis can be set symmetrically or one-sided at the desired value (see C6). At one-sided setting, the hysteresis works downward with heating contact and upward with cooling contact. At symmetrical hysteresis, half of the hysteresis' value is effective below and half of the value above the switching point.

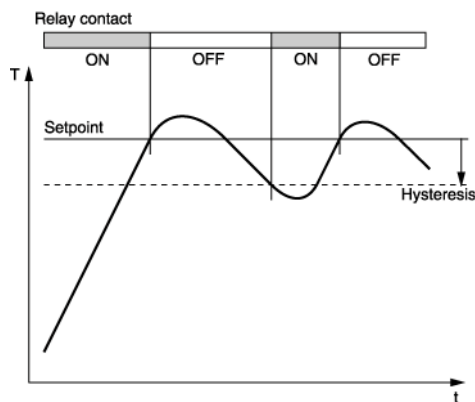

Fig. 1: Heating controller, one-sided hysteresis

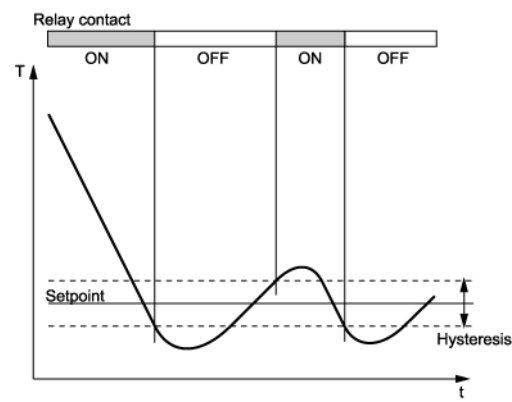

Fig. 2: Cooling controller, symmetrical hysteresis

#### C6: Hysteresis mode control circuit 1

These parameters allow selection as to whether the hysteresis values which are adjustable with C5, are set symmetrically or one-sided at the respective switching point. At symmetrical hysteresis, half of the hysteresis' value is effective below and half of the value above the switching point. The one-sided hysteresis works downward with heating contact and upward with cooling contact.

#### C7/C8: Minimum action time control circuit 1 "On"/"Off"

These parameters permit a delay in switching on/off the relay in order to reduce the switching frequency. The adjusted time sets the entire minimum time period for a switching-on or switching-off phase.

## **C9: Function control circuit 1 at sensor error**

At sensor error the selected relay (see H41, 42, 43) falls back into the condition pre-set here.

## **C10: Setpoint limit (minimum) setpoint 1**

## **C11: Setpoint limit (maximum) setpoint 1**

The adjustment range of the setpoint can be limited in both directions. This is to prevent the end user of a unit from setting inadmissible or dangerous setpoints.

## **C21: Setpoint control circuit 2 (thermostat) (b1=0)**

If  $b1=1$ , this value is ineffective.

## **C23: Value deltaW2 (b1=1)**

If  $b1=1$ , the setpoints for control circuit 1 and 2 are linked with one another via switching difference deltaW2 (C23) (operation with deltaW).

The following applies: Setpoint thermostat 2 = setpoint control circuit 1 (C1/C2) + deltaW2.

This difference can take positive or negative values. Thus, a leading or following contact can be realised.

## **C24: Switching sense control circuit 2**

The switching sense for the relays, i.e. cooling or heating function, can be programmed independently at works. Heating function means that the contact falls as soon as the pre-set setpoint is reached, thus power interruption. At cooling function the contact only tightens, when the actual value is above the required setpoint.

## **C25: Hysteresis control circuit 2**

The hysteresis can be set symmetrically or one-sided at the setpoint (see C26). At one-sided setting, the hysteresis works downward with heating contact and upward with cooling contact. At symmetrical hysteresis, half of the hysteresis' value is effective below and half of the value above the switching point (see fig. 1 and 2).

## **C26: Hysteresis mode control circuit 2**

These parameters allow selection as to whether the hysteresis values which are adjustable with C25, are set symmetrically or one-sided at the respective switching point.

At symmetrical hysteresis, half of the hysteresis' value is effective below and half of the value above the switching point. The one-sided hysteresis works downward with heating contact and upward with cooling contact.

## **C27: Minimum action time control circuit 2 "On"**

## **C28: Minimum action time control circuit 2 "Off"**

These parameters permit a delay in switching on/off the relay, in order to reduce the switching frequency. The adjusted time sets the entire minimum time period for a switching-on or switching-off phase.

## **C29: Function control circuit 2 at sensor error**

At sensor error the selected relay (see H41, 42, 43) falls back into the condition pre-set here.

## **C41: Setpoint thermostat 3 (b2=0)**

If  $b2=1$ , this value is ineffective.

## **C43: Value deltaW3 (b2=1)**

If  $b2=1$ , the setpoints for thermostat 1 and 3 are linked with one another via switching difference deltaW3 (operation with deltaW). The following applies:

Setpoint thermostat 3 = setpoint thermostat 1 (C1/C2) + deltaW3.

This difference can take positive or negative values. Thus a leading or following contact can be realised.

#### **C44: Switching sense control circuit 3**

The switching sense for the relays, i.e. cooling or heating function, can be programmed independently at works. Heating function means that the contact falls as soon as the pre-set setpoint is reached, thus power interruption. At cooling function the contact only tightens, if the actual value is above the required setpoint.

#### **C45: Hysteresis control circuit 3**

The hysteresis can be set symmetrically or one-sided at the setpoint (see C6). At one-sided setting, the hysteresis works downward with heating contact and upward with cooling contact. At symmetrical hysteresis, half of the hysteresis' value is effective below and half of the value above the switching point (see fig. 1 and 2).

#### **C46: Hysteresis mode control circuit 3**

These parameters allow selection as to whether the hysteresis values which are adjustable with C45, are set symmetrically or one-sided at the respective switching point. At symmetrical hysteresis, half of the hysteresis' value is effective below and half of the value above the switching point. The one-sided hysteresis works downward with heating contact and upward with cooling contact.

#### **C47: Minimum action time control circuit 3 "On"**

#### **C48: Minimum action time control circuit 3 "Off"**

These parameters permit a delay in switching on/off the relay in order to reduce the switching frequency. The adjusted time sets the entire minimum time period for a switching-on or switching-off phase.

#### **C49: Function control circuit 3 at sensor error**

At sensor error the selected relay (see H41, 42, 43) falls back into the condition pre-set here.

#### **C61: Lower alarm value**

#### **C62: Upper alarm value**

The exit alarm is a boundary alarm or a range alarm with one-sided hysteresis (see parameter C65). Both at the boundary alarm and the range alarm, limit values can be relative, i.e. going along with the setpoint C1/C2, or absolute, i.e. independent of the setpoint C1/C2. At boundary alarm the hysteresis works one-sided inwardly, and at range alarm outwardly (see fig. 3-6, next side).

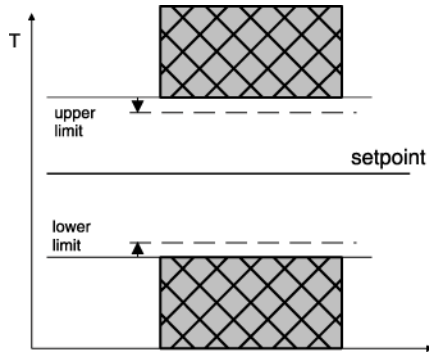

**Fig. 3:** Boundary alarm, alarm contact normal  
C63=0 limits relative  
C63=1 limits absolute

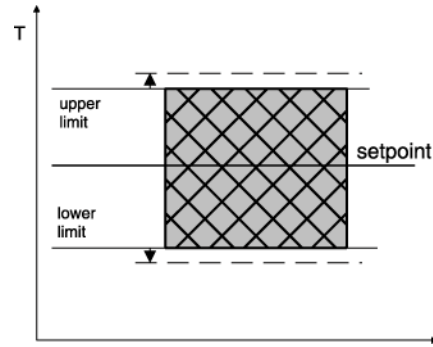

**Fig. 4:** Range alarm, alarm contact normal  
C63=2 limits relative  
C63=3 limits absolute

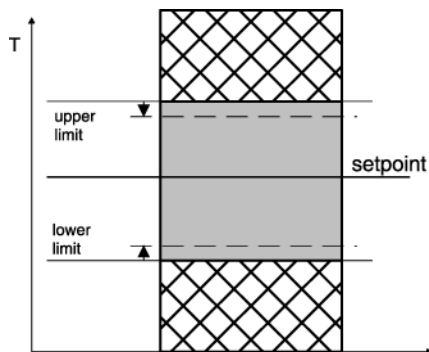

**Fig. 5:** Boundary alarm, alarm contact invers  
C63=4 limits relative  
C63=5 limits absolute

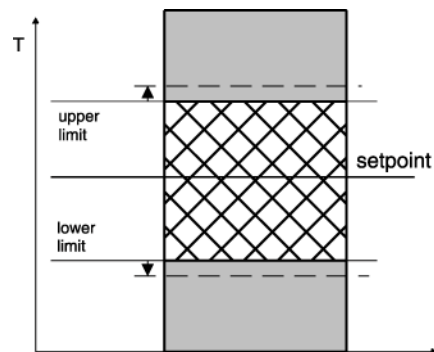

**Fig. 6:** Range alarm, alarm contact invers  
C63=6 limits relative  
C63=7 limits absolute



### C63: Function exit alarm

The exit alarm evaluates an upper and a lower limit value (see parameters C61 and C62), whereas a selection is possible as to whether the alarm is active if the temperature lies within these two limits, or whether the alarm is released if the temperature lies beyond them. In the case of sensor error, the alarm is activated independently of this adjustment. The exit can also be inverted, so that it functions like a release (see fig. 3 – 6).

### C64: Special function at alarm

Here can be selected whether, in the case of emergency, the indication to flash and/or the buzzer is to start. Sensor alarm (display F1L or F1H) is indicated independently thereof by flashing display and the buzzer runs off.

### C65: Hysteresis alarm circuit

Hysteresis is set one-sided at the adjusted limit value. It becomes effective depending on alarm definition (see fig. 3-6).

### C99: Password

This parameter is to set the password for the C—level.

## **b-level (between)**

This level contains the parameters for different combinations.

<b>Parameter</b>	<b>Function</b>	<b>Adjustment range</b>	<b>Standard setting</b>	<b>Custom setting</b>
<b>b1</b>	Activation setpoint combination for thermostat 1 and 2 (deltaW2)	0: no combination 1: Setpoint thermostat 2 = C1/C2 + C23	0	
<b>b2</b>	Activation setpoint combination for thermostat 1 and 3 (deltaW3)	0: no combination 1: setpoint thermostat 3 = C1/C2 + C43	0	
<b>b11</b>	Delay control circuit 1, 2, 3 after "Power-On"	0...400 sec.	0 sec.	
<b>b12</b>	Mutual delay control circuit 1, 2, 3	0...400 sec.	0 sec.	
<b>b13</b>	Alarm suppression after "Power-On", "setpoint"	0...60 min.	20 min.	
<b>b99</b>	Password b-level	-99 ... 999	0	

### **Parameter description b-level:**

#### **b1: Activation setpoint combination for thermostat 1 and thermostat 2 (deltaW2)**

This parameter determines whether the setpoints for thermostat 1 and 2 independently adjustable (parameter C21) or whether they are tied with one another via a switching offset deltaW2 (parameter C23).

#### **b2: Activation setpoint combination for thermostat 1 and thermostat 3 (deltaW3)**

This parameter determines whether the setpoints for thermostat 1 and 3 independently adjustable (parameter C41) or whether they are tied with one another via a switching offset deltaW2 (parameter C43).

#### **b11: Delay control circuit 1, 2, 3 after "Power-On"**

This parameter allows a switching-on delay of relays after switching-on the mains voltage. This delay corresponds with the time set here.

#### **b12: Mutual delay control circuit 1, 2, 3**

This parameter makes a mutual switching-on delay of relays possible, depending on whichever contact is switched first.

#### **b13: Alarm suppression after "Power-On", "setpoint"**

This parameter allows a switching-on delay of the alarm contact after switching on the mains voltage. This delay corresponds with the time set here.

#### **b99: Password**

This parameter is to set the password for the b—level.

### H-level (hardware)

This level contains the hardware parameters.

Parameter	Function	Adjustment range	Standard setting	Custom setting
H1	Key-lock	0: no key-lock 1: key-lock	0	
H11	Indication mode display 1	0: integrals 1: decimals in 0.5°K 2: decimals in 0.1°K	2	
H12	Display 1 mode	1: actual value 2: setpoint 3: PID variable	0	
H13	Indication mode display 2	0: integrals 1: decimals in 0.5°K 2: decimals in 0.1°K 3: decimals in 0.01°K	2	
H14	Display 2 mode	0: display deactivated 1: actual value 2: setpoint	2	
H15	Temperature scale	0: Celsius 1: Fahrenheit	0	
H16	Indication standby	0: display deactivated (point to the right) 1: AUS 2: OFF	1	
H17	Mode following "Power-On" "	0: Off 1: On 2: Auto	1	
H31	Assigning function key 1	0: no function 1: standby key 2: setpoint 1 / setpoint 2	0	
H35	Activation of key acknowledgement	0: no key acknowledgement 1: key acknowledgement with buzzer	0	
H41	Function output K1	0: no connection 1: thermostat 1 2: thermostat 2 3: thermostat 3 4: alarm function	1	
H42	Function output K2	see H41	0	
H43	Function output K3	see H41	0	
H44	<i>Function hybrid output K1</i>	<i>see H41</i>	0	
H51	Mains frequency	0: 50Hz 1: 60Hz	0	
H99	Password H-level	-99..999	0	

## Parameter description H-level:

### H1: Key-lock

The key-lock allows blocking of the control keys. In locked condition parameter adjustments with keys is not possible. At the attempt to adjust the parameters despite key-lock the message "====" appears in the display.

### H11: Indication mode display 1

The value can be indicated in integrals or with decimals in 0.5°K or 0.1°K. At indication in 0.5°K the value is rounded up or down. In general, all parameter indications are presented in 0.1°K.

### H12: Display 1 mode

H12=1 indicates the actual value and H12=2 indicates the setpoint C1 or C2 in the display. Therefore, the current actual value can only be indicated with parameter A01.

### H13: Indicator mode display 2

The value can be indicated in integrals or with decimals in 0.5°K, 0.1°C or 0.01°K. When indicating in 0.5°K, the value is rounded up or down. In general, all parameters are indicated in 0.1°C.

### H14: Display 2 mode

H14=1 indicates the actual value, H14=2 indicates the setpoint C1 or C2 and H14=3 statically indicates the PID variable in the display. H14=0 deactivates the display.

### H15: Temperature scale

Indication can be switched between Fahrenheit and Celsius. At conversion, the parameters and setpoints maintain their numerical value and adjustment range. (Example: A controller with the setpoint of 0°C is switched to Fahrenheit. The new setpoint is then interpreted as 0°F, which corresponds to a temperature of -18°C).

NOTE: Indication limits with °F can be smaller than the actual measuring range!

### H16: Indication standby

In standby mode the here set value appears in the display.

### H17: Mode following "Power-On"

After switching on the mains voltage the controller automatically goes to the condition set here. H17=2 applies to the condition prior to the separation from the net.

### H31: Assigning function key 1

Setting H31=0 deactivates the key, H31=1 functions as standby key. H31=2 thus allows to change between setpoint 1 (C1) and setpoint 2 (C2).

### H35: Activation of key acknowledgement

This parameter permits to switch the internal buzzer on/off by key confirmation.

### H41-43: Function output K1-3

#### H44: Function hybrid output K1

Generally, the exits are exchangeable with parameter adjustments, in order to achieve an optimal relation of the existing hardware with regard to contact rating, kind of contact and cycle number. Therefore, these parameters first assign the exits to the controller function. Activation of H44 deactivates H41 and H43.

### H51: Mains frequency

This parameter is to select the mains frequency.

### H99: Password

This parameter is to adjust the password for the H—level.

## d-level (defrosting functions)

This level contains the parameters for defrosting.

**NOTE:** Defrosting parameter only affects **control circuit 1**

Parameter	Function	Adjustment range	Standard setting	Custom setting
d0	Defrosting interval TH1	1 ... 99h 0: no defrosting	0	
d2	Defrosting temperature TH1	-99.0 ... 999.0°C	10.0 °C	
d3	Defrosting time limit TH1	1 ... 99 min. 0: no time limit	30 min.	
d9	Manual defrosting TH1	0...1	0	
d99	Password d-level	-99...999	0	

### Parameter description d-level:

#### **d0: Defrosting interval**

The "defrosting interval" defines the time, after which a defrosting process is started. After each defrosting start, this time is reset and runs the next interval.

#### **Manual defrosting:**

Pressing the key UP for at least 3 sec. the defrosting interval is activated earlier. Alternatively parameter d9 can be applied for this function, too. The next automatic defrosting process takes place again after the time d0. (defrosting synchronisation)

#### **d2: Defrosting temperature**

This permits to terminate defrosting when the adjusted desired temperature value is reached. The defrosting time set with "d3" nevertheless runs at the same time, i.e. it functions as safety net to terminate the defrosting process in case the defrosting temperature is not reached.

#### **d3: Defrosting time limit**

After the here set time the defrosting process is terminated.

#### **d9: Defrosting time limit**

At change of 0 -> 1 the defrosting process is started and the defrosting interval is re-set. (defrosting synchronisation)

#### **d99: Password**

This parameter is to set the password for the d-level.

## A-level (analogue values)

This level contains the parameters for analogue inputs and outputs.

Parameter	Function	Adjustment range	Standard setting	Custom setting
<b>A1</b>	Indication of actual value analogue input	-		
<b>A2</b>	Actual value correction analogue input	-99.0 ... 99.9 °K	0 °K	
<b>A3</b>	Weighing factor analogue input (without U, I-entrance)	0.50 ... 1.50	1.00	
<b>A4</b>	Sensor type	1: Thermo element type J 2: Thermo element type K 11: Pt100 two-wire 12: Pt100 three-wire 13: Pt1000 two-wire 14: Pt1000 three-wire 21: KTY81-121 two-wire	12	
<b>A5</b>	Indication value for lower value linear analogue input	-99.0 ... 999.0	0.0	
<b>A6</b>	Indication value for upper value linear analogue input	-99.0 ... 999.0	100.0	
<b>A40</b>	Time constant of the software filter	0: not active, average value with 1: 2 measuring values (2*X s) 2: 4 measuring values (4*X s) 3: 8 measuring values (8*X s) 4: 16 measuring values (16*X s) 5: 32 measuring values (32*X s) 6: 64 measuring values (64*X s) 7: 128 measuring values (128*X s)	3	
<b>A99</b>	Password A-level	-99 ... 999	0	

## Parameter description A-level:

### **A1: Indication of actual value analogue input**

The here indicated temperature value is the sum of the actual measured value of sensor F1 and the actual value correction according to parameter A2.

### **A2: Actual value correction analogue input**

With this parameter it is possible to correct actual value deviations caused by sensor tolerances or extremely long sensor lines for example. The control measuring value is increased or decreased by the here set value.

### **A3: Weighing factor analogue input (without U, I-entrance)**

With this parameter the actual value can be submitted to weighing. The measured value is multiplied by it and both indicated in the display and applied for regulation.

### **A4: Analogue input type**

These parameters permit selection of the sensor type, respectively the type of analogue input if the needed hardware prerequisites are available.

### **A5: Indication value for lower value linear analogue input**

### **A6: Indication value for upper value linear analogue input**

These parameters allow scaling of the linear analogue input. The value to be indicated for the lower and upper input value then defines the range the controller will indicate.

### **A40: Time constant of the software filter**

With several measuring values, it is possible to obtain an average value. If a sensor with a very fast reaction to external influences is used, an average value ensures a calm signal process.

### **A99: Password**

This parameter permits setting of the password for the A-level.

## Status indications and error messages

Message	Cause	Error elimination
F 1_	Sensor error (H: open-circuit or L: short-circuit at sensor F1)	Check sensor
F 2_	Sensor error (H: open-circuit or L: short-circuit at 3-wire correction)	Check sensor
E P_	0: Error program memory 1: Error parameter memory  <b>=&gt; ALL EXITS WILL BE SWITCHED OFF</b>	Repair controller
---	Display overrun or key-lock	
flashing indication	Temperature alarm at too high or too low temperatur (if activated)	

If an error is recognised in the parameter memory (indication EP) and therefore the saved settings cannot to be used, relays are set out of power supply.

## Technical data of ST48-JAUV.100

### Measuring input:

**F1:** Type of sensor according to parameter A04

	Measuring range:
Thermocouple type J:	-99°C...+999°C (clamp compensation 25,0°C)
Thermocouple type K:	-99°C...+999°C (clamp compensation 25,0°C)
Pt100-2:	-99°C...+580°C
Pt100-3:	-99°C...+450°C (max. 2x 20R resistance for the cable)
Pt1000-2:	-99°C...+400°C
Pt1000-3:	-99°C...+400°C (max. 2x 20R resistance for the cable)
PTC:	-50°C...+150°C

Measuring accuracy at 25°C: +/- 0,5% of scale range

### Output

**K1:** Relay, normally-open contact, 8(1,5)A 250V, function according to parameter H41

**Attention: use only as low voltage output!**

### Display

One 3 digit LED-display, 13mm high, colour red

One LED, diameter 3mm, for status display of output K1

### Power supply

16-36 V DC or 12-24 V AC +/-10 %, (50/60 Hz)

Power consumption max. 3 VA

### Connectors

Plug and socket

Terminal A: 4-pole screw terminal plug and socket, spacing 5,0 mm, for cable up to 2,5 mm<sup>2</sup>

Terminal B: 3-pole screw terminal plug and socket, spacing 3,5 mm, for cable up to 1,5 mm<sup>2</sup>

### Ambient conditions

Storage temperature: -20...+70 °C

Operating temperature: 0...+55 °C

Relative Humidity: max. 75% without dew

### Weight

approx. 140 g, without sensor

### Enclosure

Front IP65, IP00 from the back

### Installation data

Front panel: 48 x 48 mm

Panel cut-out: 45,2 x 45,2 mm

Installation depth: ca. 120 mm with connectors

Mounting by fixing strap