

ST710-XX(1)XX.10

Temperature controller

General Data

The control unit ST710-XX(1)XX.10 is specially designed for thermostatic control applications. The unit works together with resistance sensors (PTC or PT100).

The unit offers beyond the temperature regulation a wide range of other functions.

The output can be programmed to different functions (Parameter A1).

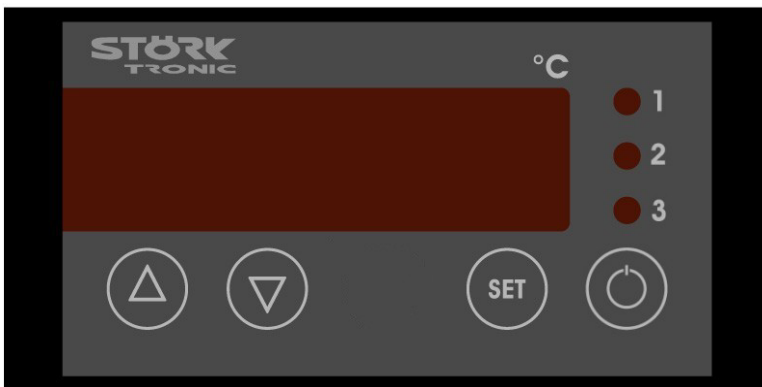

Description



key 1: UP

Pressing the the UP-key together with the SET-key increases the Setpoint value. With the UP key it is possible to start a manual defrost.



key 2: DOWN

Pressing the the DOWN-key together with the SET-key decreases the Setpoint value. With the DOWN key it is also possible to cancel the alarm buzzer.



key 4: SET

The display normally shows the actual value. When the SET button is pressed , the display changes to show the Control Setpoint.



key 5:

The Stand-By function for this key can be selected by setting the parameter A82. The key has to be pressed for at least half a second.

First level (Setpoint Adjustment)

Display of the Set Values

The display normally shows the actual value of the process temperature. When the SET button is pressed, the display changes to show the Control Setpoint (Desired temperature)

Simultaneously press the SET button with either the UP or DOWN button to increase or decrease the Setpoint. Please release the UP or DOWN button before releasing the SET button and the new value is loaded into the non-volatile memory.

Parameter	Function	Adjustable range	Standard Setting	Customer Setting
S1	Setpoint	P4...P5	0,0 °C	

Second level (P-level) Setting of control parameters

In order to prevent accidental or unauthorised changes to the pre-set parameter values, access to the P-Level has been made difficult.

Simultaneously pressing the UP and DOWN button for about 3 seconds switches the controller to the P-Level, and allows adjustment of the P parameters. The display now shows P1

To display and adjust the value of P1, press the SET button and the existing value of P1 is displayed.

By simultaneously pressing the SET button and either the UP or DOWN button this value can be increased or decreased as required. Release the UP or DOWN button before releasing the SET button and the new value is saved into the non-volatile memory.

Use the UP or DOWN button to select the remaining P-parameters, and these can be adjusted in a similar manner.

To return to the operating mode: Simultaneously press the UP and DOWN button for approx. 3 seconds and the display will again show the process temperature. In any case if no adjustment of the parameters is made for 30 seconds, the controller will automatically return to the operating mode.

Parameter	Functions	Adjustable range	Standard Setting	Customer setting
P2	Hysteresis K1	0,5...99,9 °K	1,0 °K	
P4	Control Range Limitation Minimum Setpoint	-99...P5	-99 °C	
P5	Control Range Limitation Maximum Setpoint	P4...999 °C	999 °C	
P6	Actual Value Correction	-20,0...+20,0 °K	0,0 °K	
P19	Keyboard lock (Setpoint Lock)	0: not locked 1: locked	0	
P30	Lower Boundary Value for alarm	-99...999 °C	-99 °C	
P31	Upper Boundary Value for alarm	-99...999 °C	999 °C	
P32	Hysteresis alarm values (one-side)	0,5...99,9 °K	1,0 °K	
d 0	Defrost Interval	1...99 hours 0: no defrost	0	
d 2	Defrost Temperature	-99,0...999,0 °C	10,0 °C	
d 3	Defrost Time Limit	1...99 min 0: without time limit	30 min	

Second level, P-Parameters

P2: Hysteresis K1

The hysteresis for contact K1 can be either symmetrical about the Setpoint, or to one side of the Setpoint (parameter A40). If symmetrical hysteresis has been selected, then one half of the total hysteresis is above and half below the Setpoint (see Figure 1).

If one side of Setpoint has been selected, then the total hysteresis is below the Setpoint in the heating mode and above the Setpoint in the cooling mode (see Figure 2).

Please note that small hysteresis values lead to an increased switching frequency and that the lifetime of the output relays is decreased correspondingly. In critical cases, the controller can be equipped with semiconductor relays.

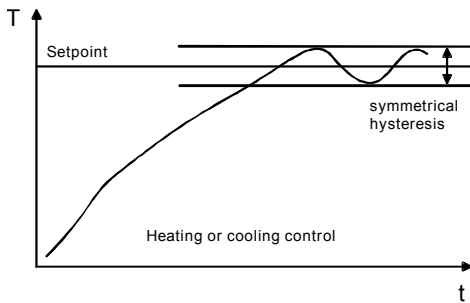

Figure 1

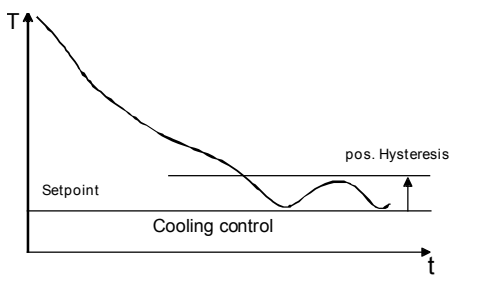

Figure 2

P4: Control range limitation - minimum Setpoint

P5: Control range limitation - maximum Setpoint

Upper and lower control range limits can be set for the Setpoint. This prevents the end user from adjusting the controller to unattainable or dangerous Setpoints.

P6: Actual value correction

A + or - calibration adjustment can be made to the Actual Value indication. It is effective over the entire measurement range.

P19: Keyboard lock

Adjustable Range: 0 = not locked
1 = locked

Standard Setting: 0

The keyboard lock disables the controller keypad and prevents operator adjustment of the Setpoint.

P30: Lower boundary value for alarm

P31: Upper boundary value for alarm

the alarm values have an adjustable hysteresis (see P32). It can be set to operate as either a boundary or a range alarm.

Boundary alarm function (see Figure 3)

LED 3 is illuminated and/or contact K3 is closed if the process temperature rises above the upper, or below the lower boundary values.

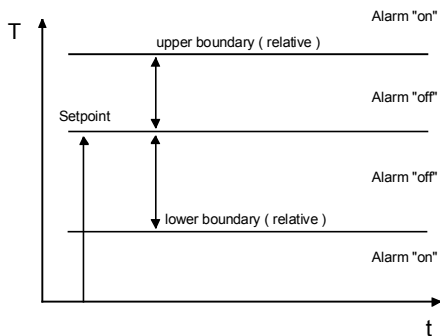

Figure 3

Range alarm function (see Figure 4)

Opposite switching behaviour to the boundary value alarm LED 3 is illuminated and/or K3 is closed if the process temperature remains between the boundary values.

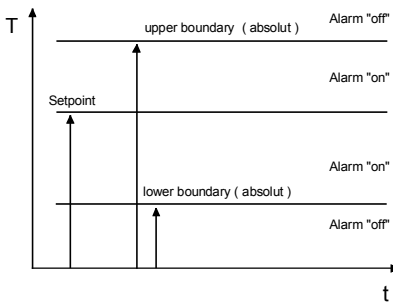

Figure 4

P32: Hysteresis alarm

The hysteresis for the alarm is always to one side of the Setpoint .
It is below the Setpoint in the upper value and above the Setpoint for the lower value.

d0 Defrost interval

This parameter determines the time interval between the start of successive defrosting periods. The initial start time is determined by the time of "Mains on".

Defrosting can be initiated by interrupting the defrosting interval in advance by a manual defrost. (Press the "UP-button for a minimum of 3 seconds)

d2 Defrost temperature

If the actual temperature is above this value defrosting ends.

d3 Defrost time limit

Defrosting ends latest as set here.

Third level (A-level)

Simultaneously press the UP and DOWN button for about 3 seconds and 'P1' appears in the display.

Press the UP button until the highest p number is displayed. Keep the UP button pressed for a further 15 seconds and the display will change to 'PA'. Simultaneously press the UP and DOWN button until 'A1' is displayed.

To return to the operating mode: Simultaneously press the UP and DOWN button for approx. 3 seconds and the display will again show the process temperature. In any case if no adjustment of the parameters is made for 30 seconds, the controller will automatically return to the operating mode.

Parameter	Functions	Adjustable Range	Standard Setting
A1	Switch mode K1	0: Heating contact 1: Cooling contact 2: Alarm contact (P30 + P31) 3: Alarm contact function inverted	1
A3	On Sensor Error (K1 Relay action)	0: Relay off 1: Relay on	0
A8	Actual value display (Parameters remain 0.1 °K resolution)	0: Whole numbers 1: 0,5 °K resolution 1: 0,1 °K resolution	1
A10	Voltage input Tu	-99...999	0
A11	Voltage input To	-99...999	100
A19	Parameter Locking	0: No lock 1: A-Parameters locked 2: A&P-Parameters locked	0
A30	Boundary Alarm (Buzzer)	0: Boundary alarm relative boundaries 1: Boundary alarm, absolute boundaries 2: Range alarm, relative boundaries 3: Range alarm, absolute boundaries	0
A31	Other alarm functions	0: Without function 1: Display flashing 2: Buzzer active 3: Display flashes and Buzzer active	0
A32	Setpoint display	0: not activated 1: Setpoint display only	0
A33	Setpoint 1' configuration	0: not activated 1: Relative to Setpoint 1 2: Freely adjustable	0
A40	Hysteresis K1	0: Symmetrical 1: One side of Setpoint	1
A50	Minimum ON Time K1	0...999 sec	0 sec
A51	Minimum OFF Time K1	0...999 sec	0 sec
A54	Time Delay relay K1 after Mains ON	0...999 sec	0 sec
A56	Alarm Signal Delay after Mains ON	0...60 min	20 min
A60	Sensor selection	11: PT100 2-wire 12: PT100 3-wire 21: KTY81-121 2-wire 22: PT1000 2-wire 23: PT1000 3-wire	Dependent on Hardware
A80	Temperature Scale and Display at Stand-By	0: Fahrenheit and "AUS" 1: Celsius and "AUS" 2: Fahrenheit and "OFF" 3: Celsius and "OFF"	1
A81	Function E1	0: No function 1: Controller ON/OFF (Stand-By) 2: Setpoint S' activated	
A82	Function Stand-By key	0: Not activated 1: Controller ON/OFF (Stand-By)	
Pro	Program Version	-	-

Third level, A-Parameters

A1: Switch mode K1

Contact direction, i.e. cooling or heating function, can be individually set for each output relay.

Heating function - The output relay contact opens when the Setpoint is reached to switch the heating OFF

Cooling function - The output relay contact closes when the temperature is higher than the Setpoint and switches the cooling power ON.

Alarm function: - The output works with the values set in the Parameter P30 and P31. The contact direction can be inverted.

A3: Sensor error K1

In the event of sensor open circuit or sensor short circuit, "F1-" flashes in the display.

Should this occur, each output relay can be independently programmed to switch ON or OFF..

A8: Display mode

Option for setting the resolution of the display .

A10/A11: Voltage input Tu/To

Only relevant if the controller is programmed for a voltage input (0-10 V or 2-10 V linear) or a current input (0-20 mA or 4-20 mA linear).

These parameters enable any desired operating values to be set against minimum and maximum input signals (setting the range equivalents for input signal values).

Note: For input ranges 2-10 V and 4-20 mA, the display will show "sensor error" codes if the input signal is more than 5% outside the measuring range. (e.g. 0 V or 0 mA)

A19: Parameter locking

Allows graduated locking of the individual parameter levels.

A30: Boundary Alarm function: (A1 set to 2 or 3)

Boundary alarm:

If A1 is set to 2, K1 switches ON (contacts close) when the process temperature is above the upper or below the lower boundaries.

If A1 is set to 3, K1 switches OFF (contacts open) when the process temperature is above the upper or below the lower boundaries.

Range alarm:

If A1 is set to 2, K1 switches ON (contacts close) when the process temperature is between the upper and lower boundaries.

If A1 is set to 3, K1 switches OFF (contacts open) when the process temperature is between the upper and lower boundaries.

Boundary values are either relative to the Setpoint, (relative boundaries) or have absolute temperature values (absolute boundaries).

A31: Other Alarm functions:

These parameters give the choice of a steady or flashing display with or without buzzer under alarm conditions.

A32: Setpoint display:

The standard setting displays the process temperature. Setpoint 1 can be displayed momentarily by pressing the SET button.

If setting 1 is chosen then the display shows Setpoint 1 only. i.e. there is no facility for displaying the process temperature.

A33: Setpoint 1* configuration.

Dependent upon hardware, Setpoint 1 can be provided with a second control value (Setpoint 1 *). This can be either relative to Setpoint 1 or an independent, freely adjustable, control setting.

When this function is available, selection of the active control setting is by means of an external switching input (ON/OFF).

With the switching input open, Setpoint 1 is the controlling value and its setting can be adjusted by the SET and UP or DOWN buttons.

With the switching input closed, Setpoint 1 * is the controlling value and it also can also be adjusted using the SET and UP or Down buttons.

A40: Hysteresis K1

The switch hysteresis can be adjusted to operate symmetrically or to one side about the setpoint. With operation one side of Setpoint, the hysteresis is below Setpoint in heating application, and above Setpoint in a cooling application.

A50 Minimum ON time K1

A51 Minimum OFF time K1

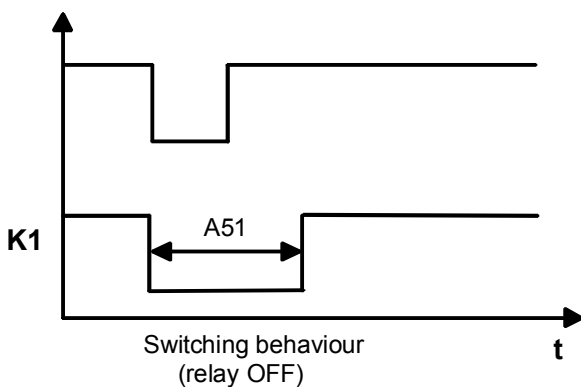
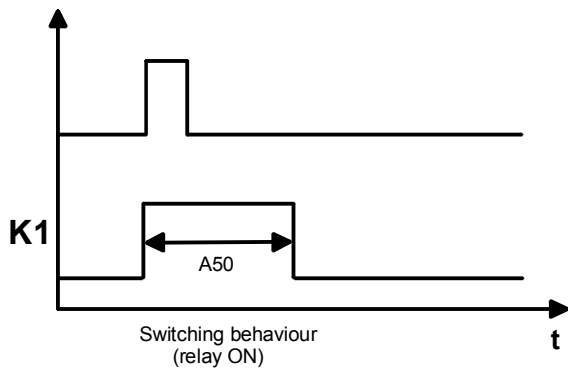

A54: Time delay relay K1 after "Mains ON"

This parameter enables the operation to be delayed for a given period after "Mains ON"

A56: Alarm delay after "Mains ON"

This time delay prevents alarms from sounding after supply voltage has been switched on

A60: Sensor selection

Depending on hardware, the regulator can be configured to the various types of sensor using this parameter.

A80: Temperature scale

This parameter enables the display to show readings in either Celsius or Fahrenheit. With this parameter you also can configure the display showing "AUS" or "OFF" at Stand-By.

A81: Function E1

A82: Function Stand-by key

Error codes

Display	error	What to do
F1L	sensor short circuit	new sensor
F1H	sensor failure	new sensor
F3L	Boundary alarm	Temperature low
F3H	Boundary alarm	Temperature high
F3	Range alarm	Temperature in between boundaries
---	Keyboard lock active	see Parameter P19 or A19
display flashing, buzzer	Temperature alarm (see A31)	cancel buzzer with ▽ button
EP	lost of data in EE-Prom	repair of controller

TECHNICAL DATA

Measuring Input

F1: Resistance thermometer KTY 81-121
 Measuring range: -50...150°C
 Measuring accuracy: +/- 1K or +/- 0,5%
 of scale range, which ever is greater
 or
 Resistance thermometer Pt100
 Measuring range: -80...400°C
 Measuring accuracy: +/- 1K or +/- 0,5%
 of scale range, which ever is greater

Output

K1: Relay, changeover contacts, 12A 250V

Display

One 3-digit, 13 mm high, red LED display

Power Supply

230V, 50Hz / 60Hz, current consumption max. 20mA

Installation Data

Front panel: 84 x 42 mm
 Panel cutout: 68 x 32 mm
 Depth: approx. 85 mm incl. terminals
 Mounting: fixing strap

Enclosure

Front IP65

Weight

approx. 200g

Ambient Conditions

Storage temperature: -20...+70 °C
 Operating temperature: 0...+55 °C
 Relative Humidity: max. 75% without dew

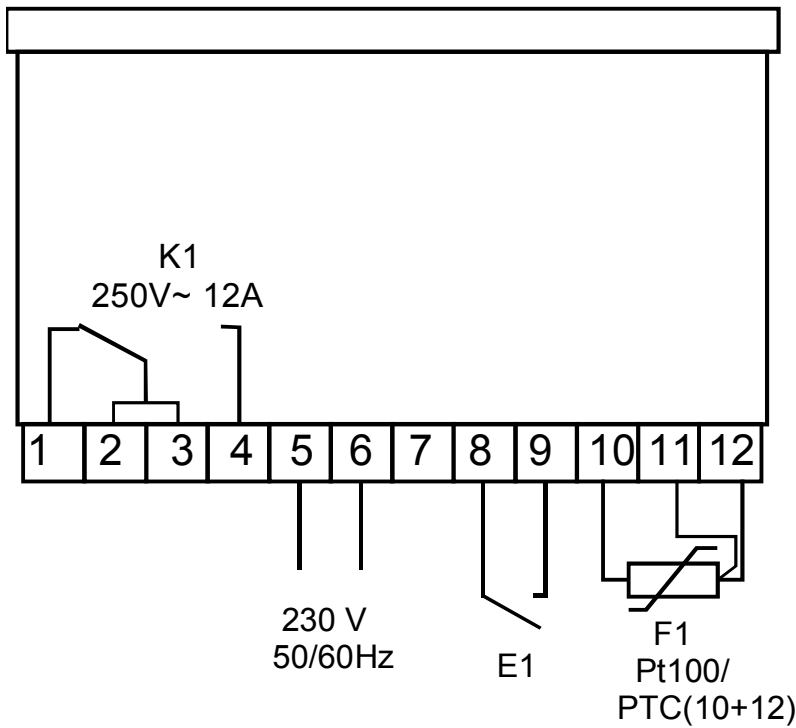

Wiring diagram version 230 V~

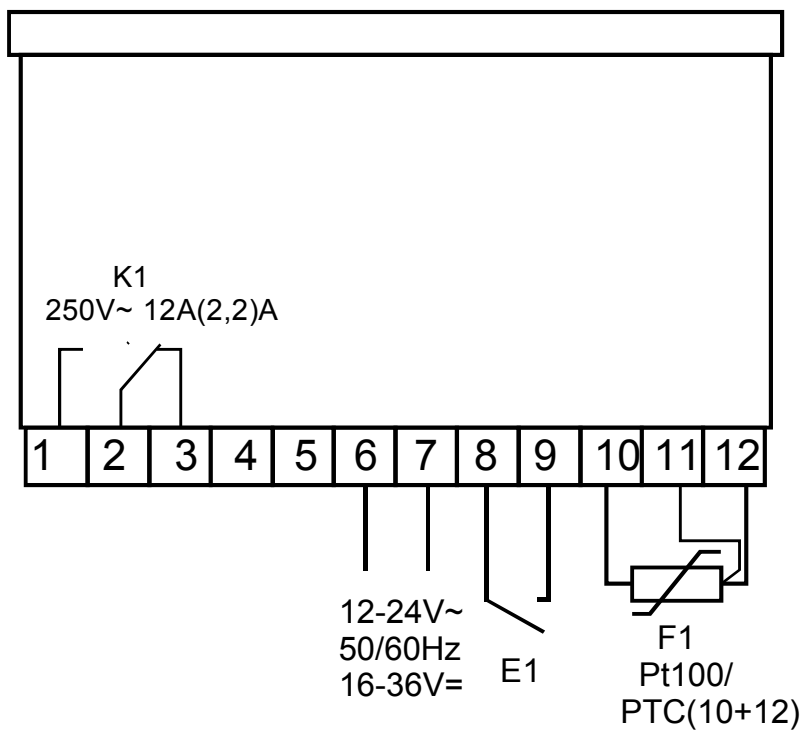

Wiring diagram version 12-24 V~/=