

## ST710-K....A.12

### Defrost controller

#### General Data

The control unit ST710-K...KA.12 is specially designed for various cooling applications. The unit works together with one sensor for the cold room and a second sensor that may control the defrost or may control the second relay by a second setpoint.

The unit offers beyond the temperature regulation a wide range of other functions.

The output can be programmed to different functions (parameter u1 + u2).

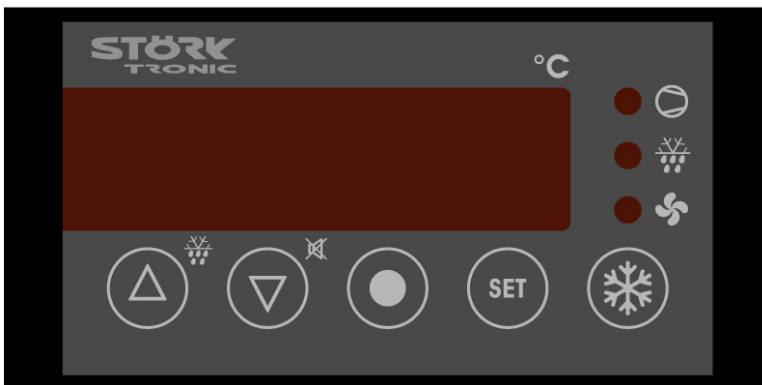

#### Description



**UP-key:**

With the UP key it is possible to start a manual defrost.

During defrost the LED is on. The LED flashes, when defrost was demanded but could not be activated because of delay times.



**DOWN-key:**

With the DOWN key it is possible to cancel the alarm buzzer.



**Key B:**

Different functions for the key „B“ can be selected by setting the parameter b2. The key has to be pressed for at least half a second.



**SET-key:**

The display normally shows the actual value (Coldroom temperature). When the SET button is pressed, the display changes to show the Control Setpoint.



**Key A:**

Different functions for the key „A“ can be selected by setting the parameter b1. The key has to be pressed for at least half a second.

## Controller

### First level (Setpoint Adjustment)

#### Display of the Set Values

The display normally shows the actual value (Coldroom temperature). When the SET button is pressed, the display changes to show the Control Setpoint (Desired Coldroom temperature)

Simultaneously press the SET button with either the UP or DOWN button to increase or decrease the Setpoint. Please release the UP or DOWN button before releasing the SET button and the new value is loaded into the non-volatile memory.

When the desired setting has been reached, the UP or DOWN button is released before releasing the SET button and the new value is loaded into the non-volatile memory. It is retained in memory even if there is a power failure.

Parameter	Function	Adjustable range	Standard Setting	Customer Setting
S1	Setpoint for the coldroom	r1...r2	0,0 °C	

The control setpoint for the coldroom can be changed through the LON bus.

### Second level

The parametring can be done in the StandBy mode.

Simultaneously press the UP and DOWN button for about 4 seconds to reach the second level. Press the UP or DOWN button to display the selected parameter. Now press the SET button to display its value.

Parameter	Function	Function	Standard Setting	Customer Setting
r0	Setpoint hysteresis	1...15 K	2 K	
P2	Actual value sensor 2	--		
Y1	Setpoint Thermostat 2 (only activ, if [P4=2])	-50...+150°C	10°K	
Y2	Hysteresis for Thermostat 2	0,5...15 K	2 K	
PA	Acess to third level Password: -19	-99...+99	0	

To select other parameters, press either the UP or DOWN button. Simultaneously press the SET button with either the UP or DOWN button to increase or decrease the parameter setting.

The parameters Y1 and Y2 are only displayed, if Thermostat 2 is configured (Parameter P4 = 2).

### Third level, all parameters

The third level contains a list of all parameters. Entry to the third level is only possible from the second level. Simultaneously press the UP and DOWN button for about 4 seconds. The display will change to shows PA. Now press the SET button and adjust the indicated value to '-19'.

Release the button and the display will show again 'PA'. Now press the UP and DOWN button simultaneously for about 4 seconds to gain entry into the third operating level beginning with parameter P0.

To select other parameters, press either the UP or DOWN button.

Select the required parameter and press the SET button to display the set value. To adjust this value, simultaneously press the SET button with either the UP or DOWN button until the desired value appears in the display. Operation of the buttons is accompanied by a momentary sound from the buzzer.

Simultaneously press the UP and DOWN button for approx. 4 seconds and the display will again show the coldroom temperature. If no adjustment is made for 45 seconds, the controller will, in any case, automatically return to the operating mode.

Parameter	Function	Adjustable Range	Standard-Setting	Customer Setting
P0	Actual value sensor 1(coldroom)			
P1	Actual value correction sensor 1	-9,9...+9,9 K	0,0 K	
P2	Actual value sensor 2 (Only available, if P4≠0)			
P3	Actual value correction sensor 2 (Only available, if P4≠0)	-9,9...+9,9 K	0,0 K	
P4	function of sensor 2	0: No sensor connected 1: sensor 2 is evaporator sensor 2: sensor 2 works for an independent Thermostat 2	1	
P5	Display mode	0: without decimal point 1: 0,5 °C resolution 2: 0,1 °C resolution	1	
P6	Temperature scale and display during Standby	0: Fahrenheit (AUS) 1: Celsius (AUS) 2: Fahrenheit (OFF) 3: Celsius (OFF)	1	
r0	Setpoint hysteresis	1...15 K	2 K	
r1	Control range limitation minimum Setpoint	-50 °C...r2	-50 °C	
r2	Control range limitation maximum Setpoint	r1...+150 °C	50 °C	
c0	Start delay after 'Mains On'	0...240 Min.	0 Min.	
c1	Start protection following 'Start'	0...15 min.	5 min.	
c2	Start protection following 'Stop'	0...15 min.	3 min.	
c3	Error-function sensor F1 (coldroom)	0: Compressor off 1: Compressor on 2: Emergency service	0	
d0	Defrost interval	0...99 hours 0=no defrost	8 hours	
d1	Type of defrost	0: Electric 1:Hot gas	0	
d2	Defrost temperature	-55...+99°C	10°C	
d3	Defrost time limit	1...99 min.	30 min.	
d6	Temperature display during defrost	0: Actual temperature 1: Temperature preceding defrost	1	
d7*	Drainage time	0...15 min	2 min.	

Parameter	Function	Adjustable Range	Standard-Setting	Customer Setting
A0	hysteresis for alarm signal	1...15 K	2 K	
A1	Low Alarm	-55...0 K	-10 K	
A2	High Alarm	0...+99 K	10 K	
A3	Alarm delay period after "Cooling On"	0...15 hours	2 hours	
A6	Alarm delay period after temperature alarm	0...240 Min.	2 min.	
A7	Alarm delay period after defrost	0...240 Min	15 min.	
A9	Switch mode alarm output	0: On at alarm 1: Off at alarm	1	
F4	Fan Operation during defrost	0: Fan independent of Defrost 1: Fan off during Defrost	1	
F5	Fan Delay Time	0...15 min.	2 min.	
F7	Fan Operation during cooling	1: always on 2: on, if compressor on 3: on, if compressor on and sensor F1 >= sensor F2	2	
Y0	type of display actual value sensor 2	0: only in parameter P2 1: Display changes between actual value sensor 1 and sensor 2 2: DOWN-button	1	
Y1	setpoint thermostat 2	-50...+150°C	10 °C	
Y2	hysteresis thermostat 2	0,5...15 K	2 K	
Y3	Control range limitation minimum Setpoint thermostat 2	-50°C...Y4	-50 °C	
Y4	Control range limitation maximum Setpoint thermostat 2	Y3...150°C	+50 °C	
Y5	Switch mode thermostat 2	0:heating contact 1:cooling contact	1	
Y6	Sensor error thermostat	0:failure switch off 1:failure switch on	1	
Y7	Defrost interval thermostat 2	0...99 hours 0=no defrost	0	
Y8	Defrost time limit thermostat 2	1...99 min.	30 min.	
b1	Function key „A“	0: no function 1: Standby 2: function defined by Ux	1	
b2	Function key „B“	0: no function 1: Setpoint thermostat 2 2: function defined by Ux, locked at Standby-Mode 3: function defined by Ux, free at Standby-Mode	0	

Parameter	Funktionsbeschreibung	Einstellbereich	Standard Wert	Kunden Werte
U1	function K1	0: No connection 1: connected to compressor 2: Connected to defrost 3: Connected to fan 4: Connected to Alarm 5: Connected to Thermostat 2 6: Connected to key „A“ 7: Connected to key „B“ 8: Connected to buzzer	1	
U2	function K2	0: No connection 1: Connected to compressor 2: Connected to defrost 3: Connected to fan 4: Connected to Alarm 5: Connected to Thermostat 2 6: Connected to key „A“ 7: Connected to key „B“ 8: Connected to buzzer	2	
U3	function K3 (or. internal buzzer, if hardware is available)	0: No connection 1: Connected to compressor 2: Connected to defrost 3: Connected to fan 4: Connected to Alarm 5: Connected to Thermostat 2 6: Connected to key „A“ 7: Connected to key „B“ 8: Connected to buzzer	0	
U4	function K4 (if hardware is available)	0: No connection 1: Connected to compressor 2: Connected to defrost 3: Connected to fan 4: Connected to Alarm 5: Connected to Thermostat 2 6: Connected to key „A“ 7: Connected to key „B“ 8: Connected to buzzer	4	

### Error messages

Message	Reason	Action
Display flashing	Coldroom temperature out of alarm boundaries (parameter A1, A2)	
E0 Display flashing	Coldroom sensor F1, failure or short circuit	New sensor Controller works defined to parameter c3
E1 Display flashing	sensor F2, failure or short circuit	New sensor See parameter c3
E2 Display flashing	Memory error	If Mains Off/On does not help you have to send the controller for repair.

If an error occurs, the error code in alternation with the actual value of sensor F1 (if working) is displayed in display. If the error is over it is possible to cancel the error code with the DOWN button

## Technical Data

### Measuring Input

**F1:** Resistance thermometer PTC(KTY81-121), coldroom

**F2:** Resistance thermometer PTC(KTY81-121), evaporator / thermostat 2

Measuring range: -50...150°C (depending on sensor)

Measuring accuracy: +/- 1K or +/- 0,5% of scale range, which ever is greater for the controller

### Display

One 3 digit LED-display, 13mm high, for temperature display, colour red

Three LED's, diameter 3mm, for status display of the outputs K1, K2 and K3(if available)

### Output

#### Version with two relays

**K1:** Relay, 16 A contact ( $\cos\varphi=1$ ), 250 V, max. constant current 10 A, normally open contact, for motor load up to 0,6HP, due to category AC15 for switching current 4 A / 250 V AC.

**K2:** Relay, 8 A-contact ( $\cos\varphi=1$ ), 250 V, max. constant current 5 A, normally open contact, for motor load up to 0,5HP

#### Version with four relays

**K1:** Relay, 8 A-contact ( $\cos\varphi=1$ ), 250 V, max. constant current 5 A, normally open contact, for motor load up to 0,5HP

**K2:** Relay, 6 A-contact ( $\cos\varphi=1$ ), 250V, max. constant current 3 A, normally open contact, function see U2

**K3:** Relay, 6 A-contact ( $\cos\varphi=1$ ), 250 V, max. constant current 3 A, normally open contact, function see U3

**K4:** Relay, 6 A-contact ( $\cos\varphi=1$ ), 250 V, max. constant current 3 A, normally open contact, function see U4

Inductive load ( $\cos\varphi=0,4$ ) max. 2 A

### Power Supply

230V, 50Hz / 60Hz, current consumption max. 4 VA

### Ambient Conditions

Storage temperature: -20...+70 °C

Operating temperature: 0...+55 °C

Relative Humidity: max. 75% without dew

### Weight

approx. 140 g, without sensor

### Connectors

12-pole Screw terminal / Screw terminal Plug and socket, Raster 5,0 mm, for vable up to 2,5 qmm

### Enclosure

Front IP65, IP00 from the back

### Enclosure

### Installation Data

Front panel 84 mm x 42 mm

Panel outcut 68 mm x 32 mm

Installation depth approx. 85 mm

Mounting by fixing strap

## Wiring diagrams ST710-K...A.12

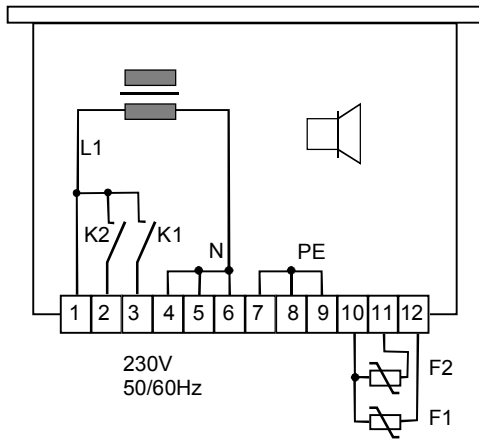

ST710-KSKA.12  
Screw terminal Plug and socket

Order No.: 220996

ST710-KS1KA.12  
Screw terminal

Order No.: 221168

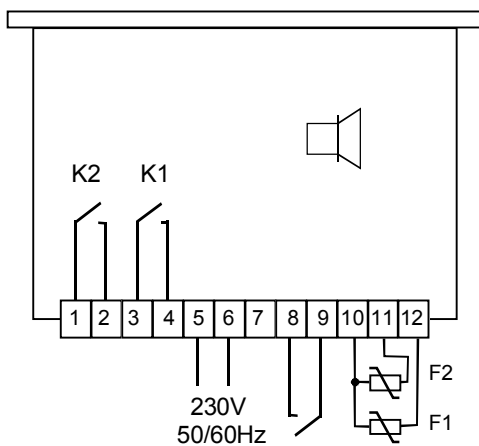

ST710-KCKA.12  
Screw terminal Plug and socket

Order No.: 126763

ST710-KC1KA.12  
Screw terminal

Order No.: 220871

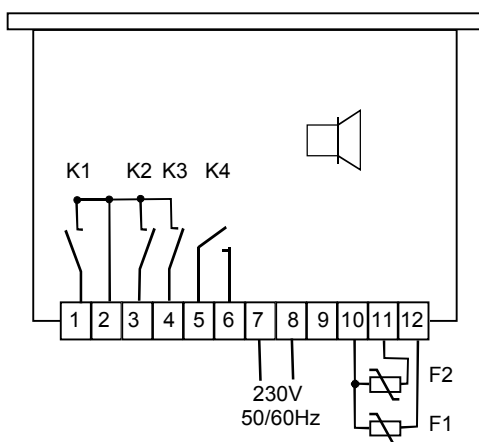

ST710-KOKA.12  
Screw terminal Plug and socket

Order No.: 292490

ST710-KO1KA.12  
Screw terminal

Order No.: 221028