

## ST121-KI1TA.12

Controller for cooling applications

Order number 233460



## Wiring diagram

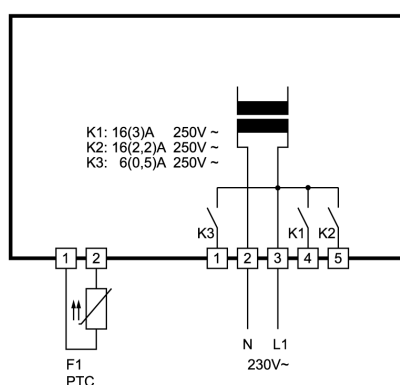

## Product description

The cooling controller ST121-KI1TA.12 with one sensor input and five keys is used for the thermostatic temperature control of refrigerating plants. It is supplied with 230V AC and has three exit relays. The function of the outputs can be adjusted to control a compressor, an evaporator sensor, a defrost device or other needed outputs.

**Sensor:** PTC

**Range:** -50...150°C

**Front size:** 120mm x 42mm

**Panel cut-out:** 102,5mm x 35mm

**Tightness:** front IP65

**Connector:** screw terminal

ST 121...

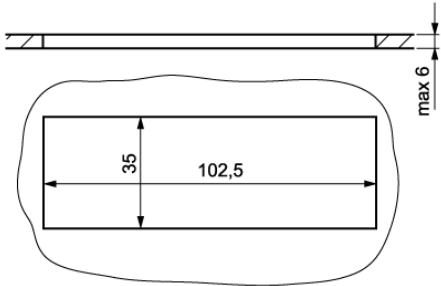
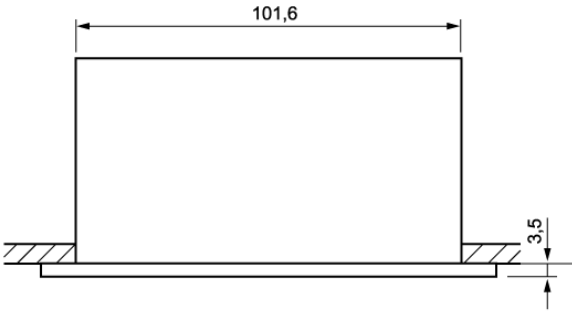
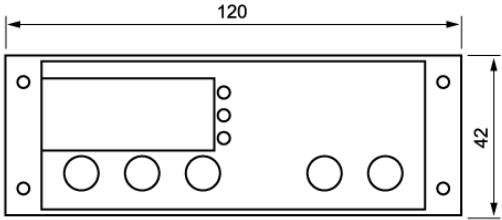

## SOFTWARE .12

### Adjustment options



#### **Key UP**

Pressing the UP key for 3 seconds initiates defrosting. During defrosting the corresponding LED lights up. The LED flashes if defrosting is requested but may not be started due to lock conditions. In addition parameters can be adjusted with this key.



#### **Key DOWN**

The DOWN key can acknowledge an alarm. The internal buzzer (if available) is then switched off. In addition parameters can be adjusted with this key.



#### **Key SET**

While SET key is pressed, the setpoint S1 is indicated. It can be adjusted by pressing the UP or DOWN key simultaneously.

In addition, the SET key is used for setting parameters.



#### **Key A**

Different functions are assigned to this key by help of parameters, see parameter b1. (direct switching of a contact, standby function...). The key must be pressed for at least half a second.



#### **Key Standby**

With this key the controller is switched to standby mode. Pressing the key a second time, restarts the unit. The key can be deactivated by setting the respective parameter, see parameter b3.

### First control level:

#### **Parameter setting for the main setpoint.**

If none of the keys is pressed, the display indicates the actual value of the temperature. Pressing the SET key, the setpoint shows on the display.

If the setpoint is to be changed, the SET key is to be kept pressed while adjusting the setpoint with the keys UP and DOWN.

Please note that the setpoint can only be changed within the set setpoint limits.

#### **General reference**

Note that the value is transferred to the captive memory and is safe also after power failure.

Para- meter	Function	Adjustment range	Standard setting	Customer setting
<b>S1</b>	Setpoint refrigerating chamber	r1...r2	2.0°C	

### Second control level:

#### Setting of control parameters

The parameters can also be set in standby mode. Simultaneously pressing the UP and DOWN key for at least 4 seconds opens a parameter list containing frequently used parameters (the complete list of all parameters is to be found on the third control level).

With the UP and DOWN keys the list can be scrolled in both directions.

Pressing the SET key will give you the value of the respective parameter. Pressing also the UP or DOWN key at the same time the value can be adjusted.

Return to the initial position takes place automatically, if no key is pressed for 45 seconds, or by simultaneously pressing the UP and DOWN key for approx. 4 seconds.

Parameter	Function	Adjustment range	Standard setting	Customer setting
r0	Hysteresis for the compressor contact	1...15 K	2 K	
P2	Indication actual value of sensor F2	-		
Y1	Setpoint thermostat 2 (only effective if [P4=2])	-50...+150°C	10.0 °C	
Y2	Switching hysteresis for thermostat 2	0.1...15.0 K	2.0 K	
PA	Access to parameter list of the third control level Password:: -19	-99...+99	0	

Parameter P2 is only indicated if P4 ≠ 0.

Parameters Y1 and Y2 are only indicated if P4=2.

### Third control level (all parameters):

#### Setting of control parameters

Access to the third control level is granted when selecting parameter PA on the second control level. Parameter PA is to be set at '-19'. Then the key UP and DOWN have to be simultaneously pressed for approx. 4 seconds which will give access to the third control level, beginning with parameter P0. With the keys UP and DOWN you can scroll the list in both directions. Pressing the SET key will give you the value of the respective parameter. By pressing the UP or DOWN key at the same time the value can be adjusted.

Return to the initial position takes place automatically, if no key is pressed for 45 seconds, or by simultaneously pressing the UP and DOWN key for approx. 4 seconds.

Parameter	Function	Adjustment range	Standard setting	Customer setting
<b>P0</b>	Indication of actual value of sensor F1			
<b>P1</b>	Calibration sensor F1, actual value correction	-99 ... 99.0 K	0.0 K	
<b>P2</b>	Indication of actual value of sensor F2 (only available if P4≠0)			
<b>P3</b>	Calibration sensor F2, actual value correction (only available if P4≠0)	-99 ... 99.0 K	0.0 K	
<b>P4</b>	Evaluation of sensor F2	0: not evaluated 1: evaluated as evaporator sensor 2: evaluated as actual value thermostat 2	1	
<b>P5</b>	Indication mode	0: integrals 1: accuracy 0.5 °C 2: accuracy 0.1 °C	1	
<b>P6</b>	Display unit, indication in standby mode	0: Fahrenheit ("AUS") 1: Celsius ("AUS") 2: Fahrenheit ("OFF") 3: Celsius ("OFF")	1	
<b>P7</b>	Sensor type (applies to both sensors)	11: Pt100 2-wire 21: PTC 2-wire 22: PT1000 2-wire	21	
<b>P8</b>	Software filter (applies to both sensors)	1: not active 2...32: average value with 2...32 measuring values	8	
<b>r0</b>	Hysteresis for the compressor contact	0.1...15.0 K	2.0 K	
<b>r1</b>	Setpoint limitation (minimum)	-50 °C...r2	-50 °C	
<b>r2</b>	Setpoint limitation (maximum)	r1...+150 °C	50 °C	
<b>c0</b>	Start protection of the compressor after "cooling on"	0...240 min.	0 min.	
<b>c1</b>	Start protection after compressor start	0...240 min.	5 min.	
<b>c2</b>	Start protection after compressor stop	0...240 min.	3 min.	

Parameter	Function	Adjustment range	Standard setting	Customer setting
<b>c3</b>	Function in the case of error of sensor F1	0: relay off 1: relay on 2: emergency operation	0	
<b>d0</b>	Defrosting interval	0 = inactive, no defrosting 1...99 h	8 h	
<b>d1</b>	Defrosting mode	0: electrical 1: with hot gas	0	
<b>d2</b>	Defrosting temperature	-50...+150 °C	10 °C	
<b>d3</b>	Defrosting time limit	1...99 min.	30 min.	
<b>d6</b>	Indication of the refrigerating chamber temperature during defrosting	0: actual temperature 1: temperature determined just before the start of defrosting	1	
<b>d7</b>	Drainage time	0...15 min.	2 min.	
<b>A0</b>	Hysteresis for alarm	0.1...15.0 K	2.0 K	
<b>A1</b>	Minimum limit value	-99.0 ... -0.1 K; 0 = inactive	-10 K	
<b>A2</b>	Maximum limit value	+0.1...+99.0 K ; 0 = inactive	10.0 K	
<b>A3</b>	Alarm suppression time after "cooling on"	0...240 min.	120 min.	
<b>A6</b>	Alarm suppression time after temperature alarm	0...240 min.	2 min.	
<b>A7</b>	Alarm suppression time after defrosting	0...240 min	15 min.	
<b>A9</b>	Switching sense alarm contact	0: relay on 1: relay off	1	
<b>F4</b>	Defrosting behaviour	0: ventilator off during defrosting 1: ventilator on during defrosting	1	
<b>F5</b>	Ventilator deceleration time after defrosting	0...240 min.	2 min.	
<b>F7</b>	Ventilator function at cooling operation	1: always on 2: on or off together with the compressor 3: on whenever the compressor is on and sensor F2 < sensor F1	2	
<b>F8</b>	Ventilator revolution number at normal cooling operation	0..100%	100	
<b>F9</b>	Ventilator revolution number at defrosting	0..100%	100	
<b>F10</b>	Kick-start	0..60s	0	
<b>Parameters Y0...Y8 are only indicated if thermostat 2 is activated (P4=2)!</b>				
<b>Y0</b>	Indication mode of the actual value of sensor F2	0: with parameter P2 1: in turns with actual value of sensor F1 2: with DOWN key	1	
<b>Y1</b>	Setpoint thermostat 2	-50...+150°C	10.0°C	
<b>Y2</b>	Hysteresis for thermostat 2	0,1...15.0 K	2.0 K	
<b>Y3</b>	Setpoint limitation (minimum) thermostat 2	-50°C...Y4	-50 °C	
<b>Y4</b>	Setpoint limitation (maximum) thermostat 2	Y3...150°C	50.0 °C	
<b>Y5</b>	Switch mode thermostat 2	0: heating contact 1: cooling contact	1	

Parameter	Function	Adjustment range	Standard setting	Customer setting
<b>Y6</b>	Function in case of error of sensor F2	0: relay off 1: relay on	1	
<b>Y7</b>	Defrosting interval thermostat 2	0: inactive, no defrosting 1...99 h	0	
<b>Y8</b>	Defrosting time limit thermostat 2	1...99 min	30 min.	
<b>b1</b>	Function key A	0: no function 1: controller on/off (standby) 2: Setpoint thermostat 2 (Y1) 3: relay directly, switched off in standby mode 4: relay directly, regardless of standby mode 5: actual value sensor F2 (toggle)	0	
<b>b2</b>	Function key B (if available)	see b1	0	
<b>b3</b>	Function standby key	0: no function	1	
<b>U1</b>	Exit connection K1	0: no connection 1: connection to compressor 2: connection to defrost 3: connection to ventilator 4: connection to alarm 5: connection to thermostat 2 6: connection to key A 7: connection to key B 8: no connection 9: on, if controller on	1	
<b>U2</b>	Exit connection K2	see U1	2	
<b>U3</b>	Exit connection K3 (if available)	see U1	3	
<b>U4</b>	Exit connection K4 (if available)	see U1	4	
<b>U5</b>	Exit connection K5 (if available)	see U1	5	
<b>Pro</b>	Program version			

## Parameter description:

*The following values can change the equipment characteristics and are therefore to be set with utmost care.*

### **P0: Indication actual value of sensor F1**

The here indicated temperature presents the sum of actual measured value of feeler F1 and the actual value correction according to parameter P1.

### **P1: Calibration sensor F1, actual value correction**

This parameter allows the correction of actual value deviations caused for example by sensor tolerances or extremely long sensor lines. The regulation measure value is increased or decreased by the here adjusted value.

### **P2: Indication actual value of sensor F2**

The here indicated temperature presents the sum of actual measured value of sensor F2 and the actual value correction according parameter P3.

### **P3: Calibration sensor F2, actual value correction**

This parameter allows the correction of actual value deviations caused for example by sensor tolerances or extremely long sensor lines. The regulation measure value is increased or decreased by the here adjusted value.

### **P4: Evaluation of sensor F2**

Sensor F2 can be used for the determination of the evaporator temperature (P4=1) or for the second thermostat (P4=2).

If, in simpler refrigerant plants only the refrigerating chamber sensor is used, the feeler entrance for sensor F2 as well as its data recording (P4=0) can be deactivated here. Among other, parameter d2 has no meaning in the deactivated condition.

### **P5: Indication mode**

The actual value can be indicated with different accuracy.  
Actual values and parameter values are always set for highest accuracy.

### **P6: Display unit, indication in standby mode**

This parameter allows display settings (°F or °C) and ("AUS" or "OFF") in standby mode.

### **P7: Sensor type**

This parameter makes it is possible to adjust the feeler type of both sensors. Depending on the hardware not all sensor settings are possible.

### **P8: Software filter**

This parameter can determine by how many measured values an average value is to be formed.

### **r0: Hysteresis for the compressor contact**

Parameter r0 sets the temperature margin between switching off and switching on of the compressor. A small hysteresis permits a more exact regulation, however also leads to more frequent switching of the compressor. The hysteresis is set one-sided above the setpoint.

### **r1: Setpoint limitation (minimum)**

### **r2: Setpoint limitation (maximum)**

These parameters limit the adjustment range of the setpoint S1, in order to avoid that the end user sets inadmissible values for the plant.

The entire adjustment range is equivalent to the maximum operating range of a PTC sensor.

## **c0: Start protection of the compressor after "cooling on"**

After cooling is switched on (e.g. by switching on the mains voltage) the start of the compressor is retarded until the protection running time is over. This secures e.g. that several cooling units do not start at the same time and load the electricity supply net.

## **c1: Start protection of the compressor after compressor start**

This time protection starts when the compressor is switched on. After switching the compressor off, a renewed switching on is impossible until this protection time runs out. This prevents from too frequent switching-on of the compressor and thus increases its life span.

## **c2: Start protection of the compressor after compressor stop**

This time protection starts when the compressor is switched off. After switching the compressor off, a renewed switching on is impossible until this protection time runs out.

## **c3: Function in the case of error of refrigerating chamber sensor F1**

Here is determined whether the compressor keeps running or not in the case of an error of the refrigerating chamber feeler F1. When deep-freezing, the compressor should normally continue running, in order to prevent de-frosting of the goods. At the normal cooling range above 0 °C, a continuation, however, could lead to frost damages.

In the operation mode "emergency operation" the compressor is switched on and off in 5 minute intervals. This results in a cycling operation with 50 % cooling performance.

## **d0: Defrosting interval**

The defrosting interval defines the time, after which a defrosting process is started. With the beginning of the defrosting process, the defrosting interval starts anew, which results in periodic defrosting in firm intervals. Defrosting can also be started by pressing the UP key for at least 3 seconds. This automatically restarts the defrosting interval.

After switching-on cooling, the controller immediately initiates cooling and starts the first defrosting process after this interval.

## **d1: Defrosting mode**

This parameter determines whether defrosting is effected by an electrical heating coil (d1=0) or by means of hot gas (d1=1).

## **d2: Defrosting temperature**

The defrosting process is terminated when the evaporator has reached the adjusted temperature. (Always provide good thermal contact between evaporator sensors and lamellas).

In case that defrosting takes too long, the time limit set in "d3" will come into effect.

## **d3: Defrosting time limit**

Here the maximal defrosting time can be adjusted. According to this time frame, defrosting is terminated even if the evaporator is not warm enough to be ice-free.

## **d6: Indication of the refrigerating chamber temperature during defrosting**

It is to be assumed that the refrigerating chamber temperature slightly rises during the defrosting process. d6=0 indicates the actual refrigerating chamber temperature during the defrosting process. d6=1 indicates the temperature determined just before the start of defrosting until the setpoint of the refrigerating chamber is reached again after the defrosting process is completed. Thus, an irritation of the operator during defrosting can be avoided. In the case of emergency, the display flashes and the actual temperature of the refrigerating chamber is indicated.

## **d7: Drainage time**

Completed defrosting is immediately followed by a drainage period, in order to let the evaporator drip off. During drainage time, the exits compressor and ventilator are switched off.

## **A0: Switching hysteresis for alarm**

The hysteresis of the alarm contact is asymmetrically, set downward at the maximum alarm value upward at the minimum alarm value.

## **A1/A2: Minimum/maximum limit values**

The limit values serve for monitoring of the refrigerating chamber temperature. They are relative, i.e. going along with the setpoint S1 of the refrigerating chamber. Alarm is released when exceeding maximum limit value or when falling below the minimum limit value:

The actual value display flashes, the buzzer (if available) goes off intermittently and the actual temperature of sensor F1 is indicated (if there is no sensor error).

At A1=0 or A2=0 the respective limit value alarm is inactive.

The buzzer can be turned off with the DOWN key, the display continues flashing until the alarm is turned off.

## **A3: Alarm suppression time after “cooling on”**

After switching cooling on, an alarm is suppressed for the adjusted time, i.e. the refrigerant plant can get to work temperature without releasing alarm.

## **A6: Alarm suppression time after temperature alarm**

If the refrigerating chamber temperature exceeds the limit values adjusted at A1, A2, normally a temperature alarm should be released.

With the suppression time set at A6 the alarm release can be delayed.

## **A7: Alarm suppression time after defrosting**

Temperature alarm is avoided for the adjusted time after defrosting, in order to enable the plant to get back to the normal operating conditions (see A1, A2).

## **A9: Switching sense alarm exit**

Depending on application, the alarm exit requires a normally-closed or a normally-open contact. At setting A9=1 the relay tightens in normal operation and opens in the case of emergency. That way also a voltage failure of the controller can be detected (relay dead = alarm) for an external alarm chain.

## **F4: Defrosting behaviour**

At F4=0 the ventilator is switched off during defrosting.

At F4=1 the ventilator continues to run also during defrosting (normal cooling range above 0°C).

## **F5: Ventilator deceleration time after defrosting**

Following drainage time d7, start of the ventilator can be delayed until the evaporator has sufficiently cold air again. If the ventilator started immediately, the warm air resulting from the defrosting process would probably be blown into the refrigerating chamber.

## **F7: Ventilator function at cooling operation**

At F7=1 the ventilator is always on (except possibly for a defrosting process, see parameter F4).

At F7=2 the ventilator is always on or off together with the compressor.

At F7=3 the ventilator is switched on whenever the compressor is on and the evaporator temperature (sensor F2) is below the refrigerating chamber temperature (sensor F1). The ventilator is switched off whenever the evaporator is switched off, whereas parameter F5 is not active. In the case of sensor error the ventilator reacts as in the setting F7=2.

## **F8: Ventilator revolution number at normal cooling operation**

This parameter determines the ventilator revolution number at normal cooling operation.

## **F9: Ventilator revolution number at defrosting**

This parameter determines the ventilator revolution number at defrosting.

## **F10: Kick-start (in seconds)**

If necessary, this is an option to set a time during which the ventilator starts with the maximum number of revolutions for stable operation. This parameter is only efficient, if the ventilator is newly started.

## **Y0: Indication mode of the actual value of sensor F2**

At Y0=0 the actual value of sensor F1 is always indicated. The actual value of sensor P2 can be indicated with parameter P2 (second control level).

At Y0=1 the actual values of sensors F1 and F2 are indicated in turns every approx. 4 seconds. To distinguish them, the display marks the respective actual value with "F1" and "F2" for approx. 1 second.

At Y0=2 the display switches between the actual values for F1 and F2, if the accordingly parametered (b1=5) key A is pressed.

## **Y1: Setpoint thermostat 2**

In case that sensor 2 is not used as evaporator sensor, but as actual value for a second independent thermostat, Y1 has the function of setting the setpoint for the latter. If parameters of key B are set appropriately (parameter b2=2), the setpoint can also be adjusted directly with the respective function key.

## **Y2: Hysteresis thermostat 2**

The hysteresis is set asymmetrically at the desired value. At cooling contact the hysteresis works on one-sided upward and at heating contact one-sided downward.

## **Y3/Y4: Setpoint limitation (maximum/minimum) thermostat 2**

These parameters limit the adjustment range of the desired value Y1, in order to avoid that the end user sets inadmissible values for the plant. The entire adjustment range is equivalent to the maximum work range of the PTC sensor.

## **Y5: Switch mode for the exit of thermostat 2**

Heating function means that the contact falls when the pre-set desired value is reached, i.e. power interruption. In cooling functions the contact only tightens if the actual value is above the pre-set desired value.

## **Y6: Function at error of sensor F2**

Here is determined whether the respective output contact drops or tightens in case of a sensor F2 error.

## **Y7: Defrosting interval thermostat 2**

The defrosting interval defines the time, after which each defrosting process starts. With the beginning of the defrosting process, the defrosting interval starts anew, which results in the periodic defrosting in firm intervals.

## **Y8: Defrosting time limit thermostat 2**

Here the maximal defrosting time can be set.

## **b1: Function key A**

### **b2: Function key B (if available)**

At setting = 0 the respective key has no function.

At setting = 1 the controller is switched to standby mode

At setting = 2 the key is linked with the function "indicate/adjust setpoint Y1 for the thermostat 2"

At setting = 3 a relay (indicated with parameter Ux) can be switched on or off directly with the key.

In standby mode the key is locked and the corresponding relay switched off. After restarting the corresponding relay remains switched off.

At setting = 4 a relay (indicated with parameter Ux) is switched despite of the standby mode. The condition of the exit is maintained until the key is pressed again or until it is changed by an external switching entrance. After net interruption, the condition before power failure is re-installed.  
 At setting = 5 the actual value of sensor 2 can be indicated. At setting P4=0 the key has no function.

### b3: Function key 3 (standby)

At setting b3=0 the function of the key can be deactivated.

### U1: Exit connection K1

### U2: Exit connection K2

### U3: Exit connection K3

### U4: Exit connection K4

### U5: Exit connection K5

Depending on existing hardware there may not be all output relays. This parameter assigns the respective relay to the internal controller exits or to function key A or B.

At setting =6 or =7 the relay is switched manually. It changes its condition with each pressure of the key and adopts the condition of the respective switching entrance whenever the latter changes. If the corresponding key has not been released for this function (see parameters b1, b2), the relay remains switched off.

### Pro: Program version

This parameter shows the program version.

## Status messages

Message	Cause	Error elimination
<b>ON/OFF</b>	Standby modus, no regulation	Switch on by key or switching input
<b>Temperature indication flashes</b>	Refrigerating chamber temperature beyond alarm limits (parameter A1, A2)	
<b>E0 flashes</b>	Refrigerating chamber sensor F1 error, open or short circuit	Check sensor. Controller operates according to with parameter c3.
<b>E1 flashes</b>	Sensor F2 error, open or short circuit	Check sensor. At setting [c3=1] the controller operates in timed defrosting modus (defrosting time as set in d3). At setting [c3=2] see parameter Y6.
<b>EP</b>	Data loss at parameter memory (basic contact 1 and 2 are dead)	If error cannot be eliminated by switching on/off, the controller must be repaired.

Error message EP changes in the display with the actual value of sensor F1, unless the latter is defective. This happens independently from the selected indication mode. After the error is eliminated and confirmed with the DOWN key, the previously set indication mode becomes active again.

## Technical data of ST121-KI1TA.12

### Measuring input

**F1:** Temperature sensor refrigerating chamber  
Measuring range: PTC (KTY81-121) -50°C...+130°C

Accuracy:  $\pm 0.5K \pm 0.5 \%$  at 25°C, without sensor  
 $\pm 1K \pm 0.5 \%$  of scale range (0...+55°C), without sensor

### Outputs

**K1:** Relay, normally-open contact, 20(3)A 250V~,  
permanent current max. 16(3)A, limited by connectors and/or conductive strips

**K2:** Relay, normally-open contact, 16(2.2)A 250V~

**K3:** Relay, normally-open contact, 6(0.5)A 250V~

Please note: K1, K2 and K3 have a common and potential-afflicted connection.  
The total current at terminal X2, Pin 3 may not exceed 16A!

### Display

One 3-digit LED-Display, height 13 mm, colour red  
3 LEDs, diameter 3mm, colour red, for status display of compressor, fan, defrost

### Power supply

230V~ 50/60 Hz, power consumption max. 10 VA

### Connectors

screw terminal

X1: 3 pole, spacing 5.0 mm, for cable up to 2.5 mm<sup>2</sup>

X2: 5 pole, spacing 5.0 mm, for cable up to 2.5 mm<sup>2</sup>

### Ambient conditions:

Storage temperature: -20...+70°C

Operating temperature: 0...+55°C

Relative humidity: max. 75% without dew

### Weight

ca. 300 g, without sensor

### Enclosure

Front IP65, IP00 from back

### Installation data

Front size: 120 x 42 mm

Panel cut-out: 102.5 x 35 mm

Installation depth: max. 47mm